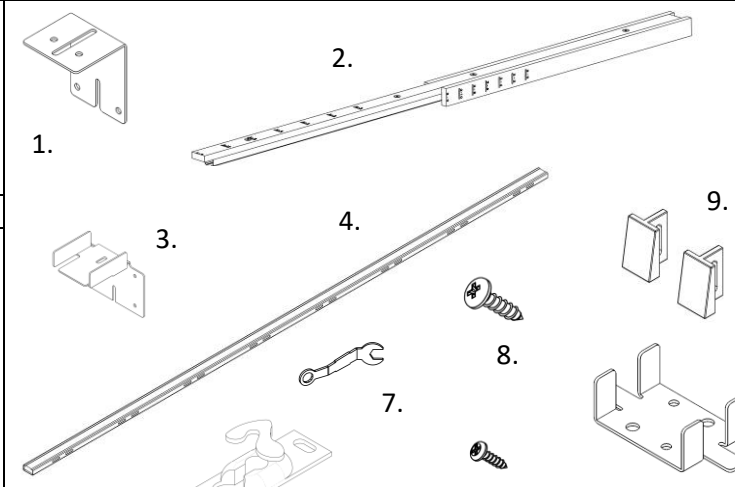
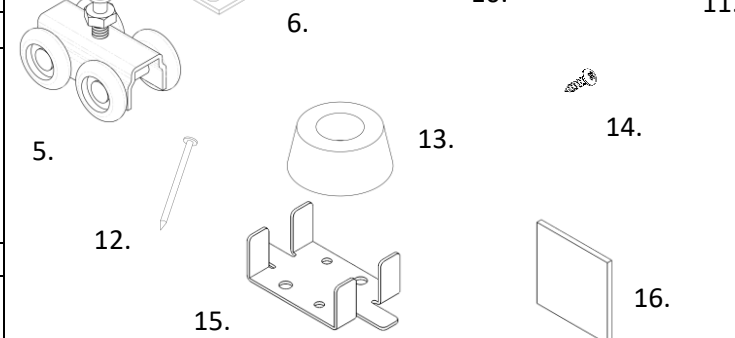

Contents:	Qty:	
1. Doorway End Bracket	1	
2. 2" x 4" Header and Track Assembly	1	
3. Pocket End Bracket	1	
4. Split Stud	4	
Non-Ball Bearing 4-wheel Hanger Parts Bag - 150lb (9805)		
5. Non-Ball Bearing 4-wheel Roller - 150lb	2	
6. Hanger Plate	2	
7. Hanger Wrench	1	
8. M5.5 x 32mm PPHW Hanger Plate Screw	4	
9. Floor Guide (9883CS)	2	
10. M4.2 x 13mm Washer PPHW Floor Guide Screw	2	
Floor Plate Parts Bag for Doors up to 1-3/8" Thick		
11. Floor Plate for Doors up to 1-3/8" Thick	2	
12. Nails	12	
13. Rubber Bumper (9881CS)	1	
14. #8 x 5/8" PPHW Screw	3	
1-3/4" Adapter Kit (9634CS)		
15. Floor Plate for 1-3/4" Thick Doors	2	
16. 1/8" Thick Shim	4	

1 Prepare the Rough Opening

Part Number	Nominal Door Height (NDH)	Rough Opening Height from Finished Floor	Bracket Fastener Height from Finished Floor
9631CS	6'-8" Door	84-1/2"	80-3/4"
9630CS	7'-0" Door	88-1/2"	84-3/4"
9629CS	8'-0" Door	100-1/2"	96-3/4"
9628CS	9'-0" Door	112-1/2"	108-3/4"
	Custom	NDH + 4-1/2"	NDH + 3/4"

Nominal Door Width (NDW)	Rough Opening Width	Header Length	Nailing Board Length
3'-0"	73"	72-5/8"	36-7/8"
2'-10"	69"	68-5/8"	34-7/8"
2'-8"	65"	64-5/8"	32-7/8"
2'-6"	61"	60-5/8"	30-7/8"
2'-4"	57"	56-5/8"	28-7/8"
2'-2"	53"	52-5/8"	26-7/8"
2'-0"	49"	48-5/8"	24-7/8"
Custom	(2 x NDW) + 1"	(2 x NDW) + 5/8"	NDW + 7/8"

- Measure the rough opening using Table 1 and 2 or Figure 1
- Plumb the rough studs and ensure the floor is level

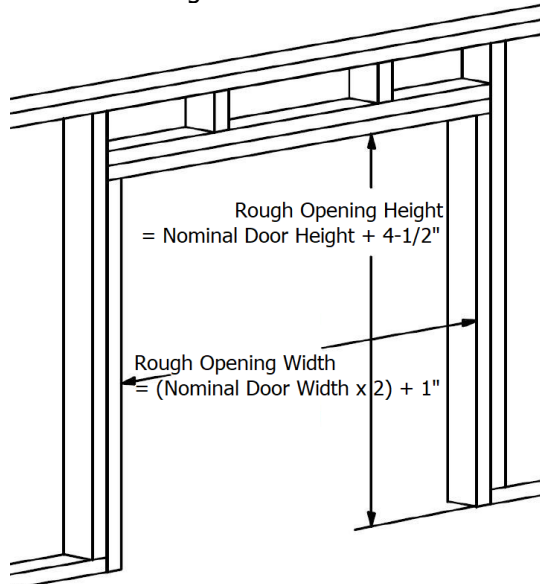

Figure 1

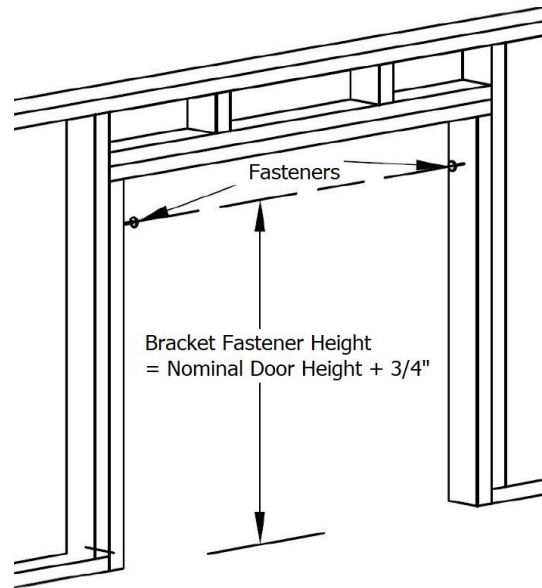

Figure 2

2 Mount the Header Brackets

- Using Table 1 or Figure 2, mark the bracket fastener height on each side of the rough opening.
 Note: If measuring from a rough sub-floor, make sure to add the estimated thickness of the finished floor material and/or carpeting.
- Drive a fastener (not included) on the centerline of each rough stud at the height marked on the previous step. Leave 1/8" (3.17 mm) of the fastener protruding.
 Note: Fastener used is based on the material of the rough studs
- Slide each end bracket's slot in the fastener heads. Make sure to use the pocket end bracket for the pocket side rough stud and doorway end bracket for the doorway side rough stud. See Figure 6.
- Level the brackets
- Drive the fastener all the way in
- Drive additional fasteners to secure the brackets

3 Mount the Frame Hardware

- Prepare the header and track assembly
 Note: The header and track assembly on each kit will fit a 3'-0" (91.44 cm) door. However, the header and track assembly can easily be cut to accommodate shorter size door as shown below using the dimensions from Table 2.

a. Cut the wood header to the desired length (Table 2)

b. Turn the header on its side to cut the nailing boards to the desired length. Make sure not to cut the track or the wood header. (Table 2)

c. Turn the header and track assembly back over and cut the track 1-1/4" (31.75 mm) from the pocket end of wood header. Make sure to cut the track only.

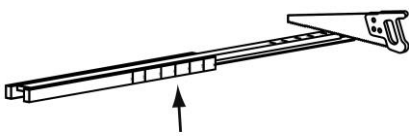

MARKINGS FOR STANDARD DOOR WIDTHS.
 Figure 3

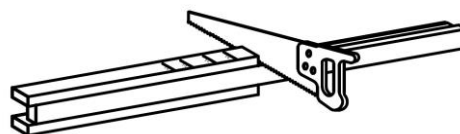

Figure 4



Figure 5

- Draw two reference chalk lines on the floor that are even with the sides of the rough studs
- Insert both 4-wheel rollers into the track before installing the header and track assembly
- Screw the header and track assembly to the attached end brackets with the #8 x 5/8" Pan Phillips Head Wood Screws. Make sure the pocket end bracket is the one attached to the pocket end of the header and track assembly. See Figure 6.

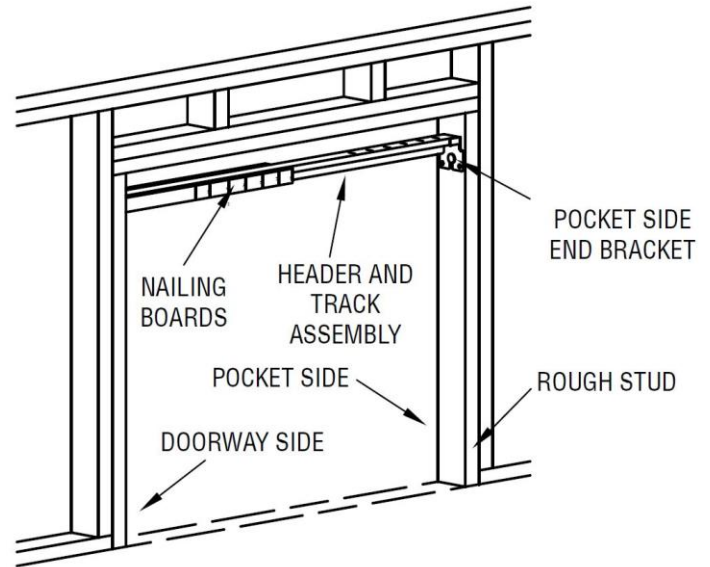

Figure 6

4 Install the Split Studs

- For doors 1-3/4" thick, see the installation instructions included in 9634CS
 - Insert the floor plates into the bottom of the split studs
- Note: The bottom of the split stud is the end without the slots as seen in Figure 7. If the split studs must be cut for shorter doors, determine which end of the split stud has the slots and cut off the other end.

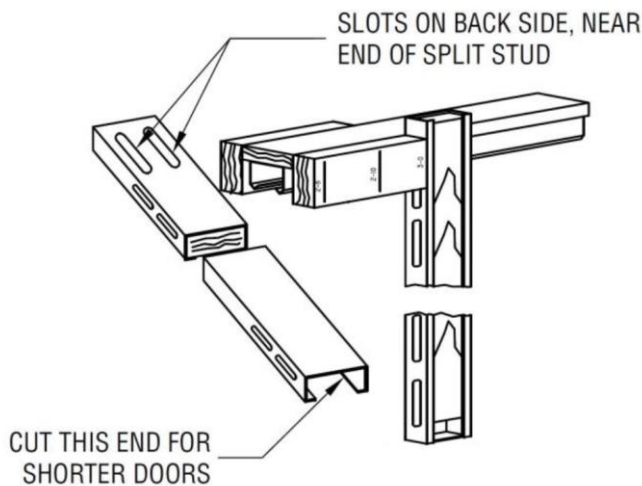

Figure 7

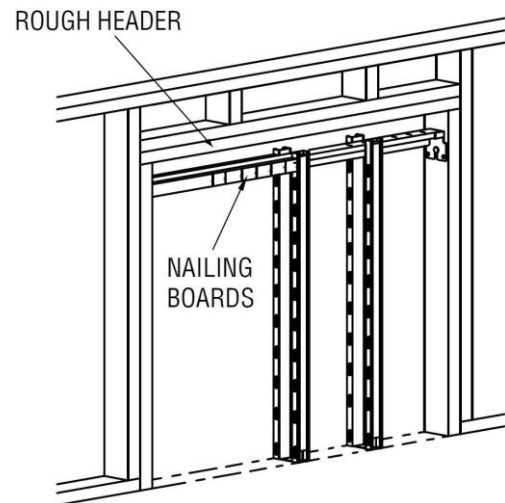

Figure 8

- Butt one pair of the split studs against the header nailing boards with the slots side against the header as seen in Figure 7
- Nail the split studs to the header while making sure the nails are driven through the center of the slots
- Nail the other pair of split studs to the header, midway between the first pair of split studs and the rough stud closest to the pocket side, as seen in Figure 8
- Note: Nails to secure the split studs to the header are included
- Position the floor plates between the chalk lines and plumb the split studs to make sure they are vertical and square
- Secure the floor plates using the appropriate fasteners (not included) for the material of the floor

5 Mount the Door Hardware

- Seal all 6 sides of the door
- Create a pilot hole using a 5/64" drill bit at the center of the pocket side door thickness, 40" from the bottom of the door. See Figure 9.
- Install the bumper using the #8 x 5/8" Pan Phillips Head Wood Screws
- Position both hanger plates center of the top door edge thickness. One 2-1/4" from the left door edge and the other 2-1/4" from the right door edge. Make sure the slots on both hanger plates are facing the pocket side door edge. See Figure 10
- Create pilot holes using a 7/64" drill bit and the hanger plates as templates
- Install the hanger plates using the M5.5 x 32mm Pan Phillips Head Wood Screws

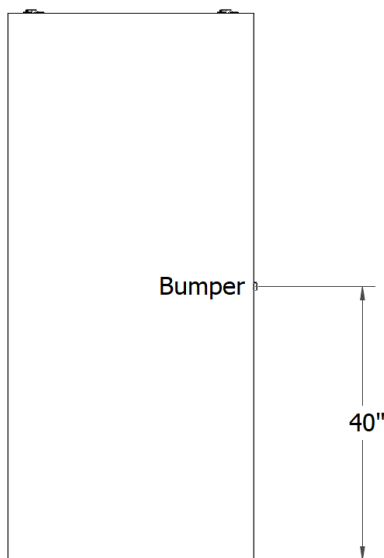

Figure 9

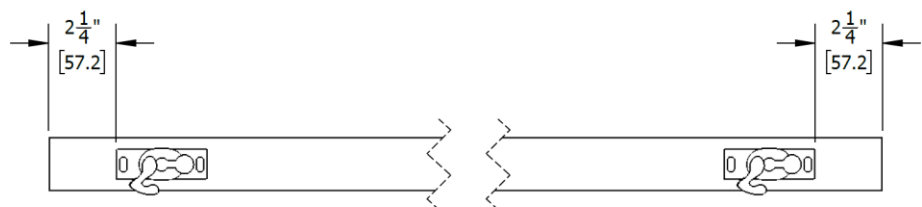

Figure 10

6 Hang the Door

- Unlatch the hanger plates
- Slide the hanger plates' slot onto the 4-wheel rollers' bolt
- Latch the hanger plates

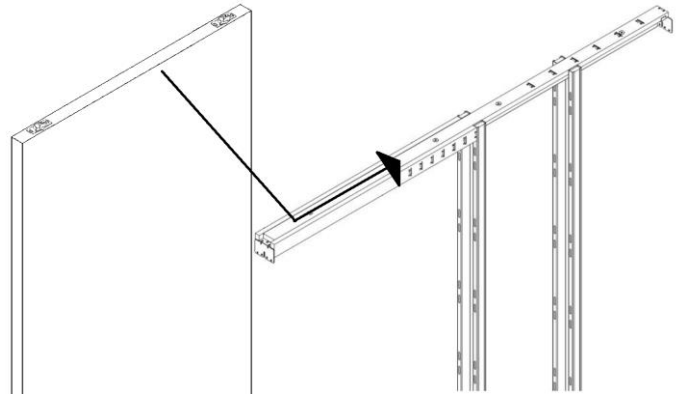

Figure 11

7 Finish the Jambs and Trim

- Apply wall material
 Note: Make sure the fastener used to apply the wall material is no longer than necessary to avoid scratching or damaging the door when opening or closing the pocket door
- Install the finish solid and split jambs by butting them all the way up against the top and bottom corners of the opening. Make sure the finish solid and split jambs are level. Use shims, as necessary.
 Note: Leave about 3/16" clearance between the finish split jamb edges and the door. See Figure 16.

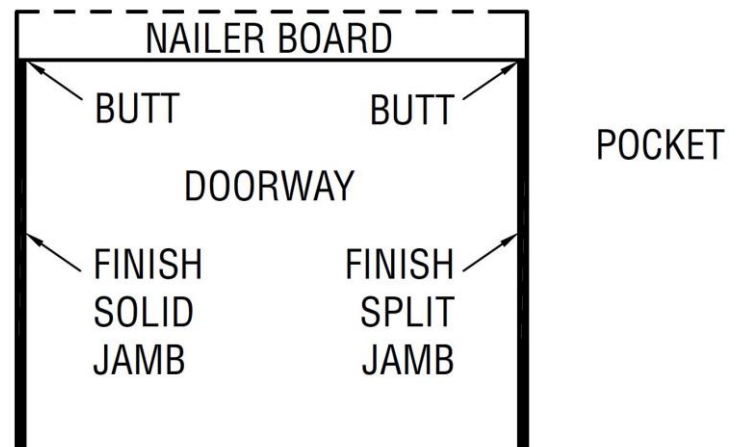

Figure 12

- Use the hanger wrench provided to adjust the door hangers. Make sure to square the door to the finish solid jamb.
 Note: There is about half an inch of adjustment that can be made with the door hangers
 Note: Leave about 3/4" clearance between the floor and the bottom edge of the door. See Figure 16.

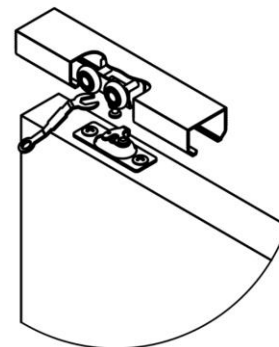

Figure 13

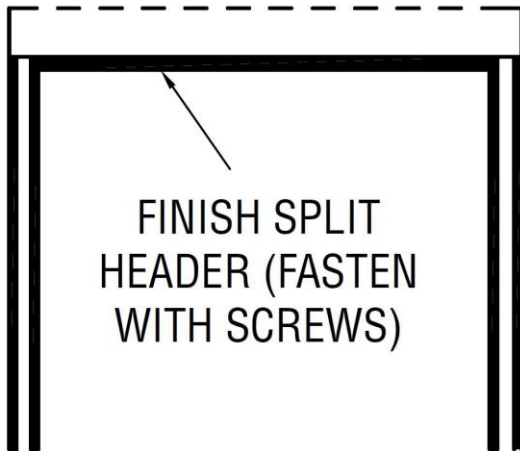

Figure 14

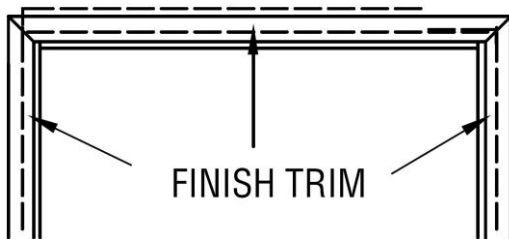

Figure 15

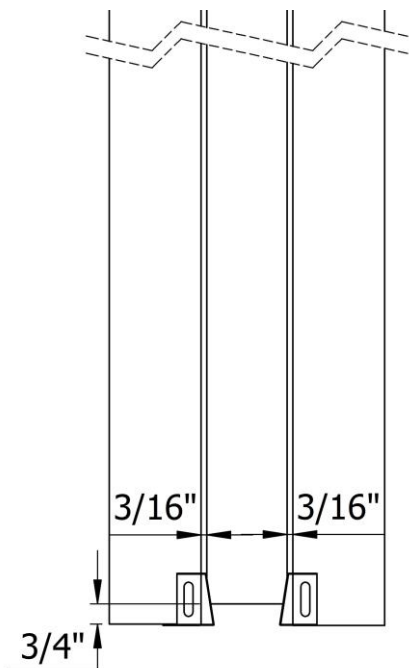

Figure 16

- Install the finish split header by butting them all the way up against the finish solid and split jamb. Make sure the finish split header is level. Use shims, as necessary.
 Note: To allow for future door adjustments or removal, at least one finished split header should be attached with screws only. The one on your right hand overhead as you face the door in the pocket is recommended.
- Install the finish trim or casing.
 Note: Make sure to fasten the finish header trim to **ONLY** the wall and **NOT** the finish split header. This ensures the finish split header can be removed later without damage.
- Create pilot holes to the finish split jamb using a 5/64" drill bit and the Floor Guide as templates. See Figure 16.
- Install the Floor Guide using the M4.2 x 13mm Washer Phillips Head Wood Screw